

Crane Scale 30Ton



Features

- ◆ High-strength steel case (RED font)
- ◆ Integrated sensor design
- ◆ American standard eye hook
- ◆ LED display, digital height 45mm
- ◆ Build-in rechargeable battery
- ◆ Remote control
- ◆ Capacity : 30T

Optional colours

Blue

Size and weight

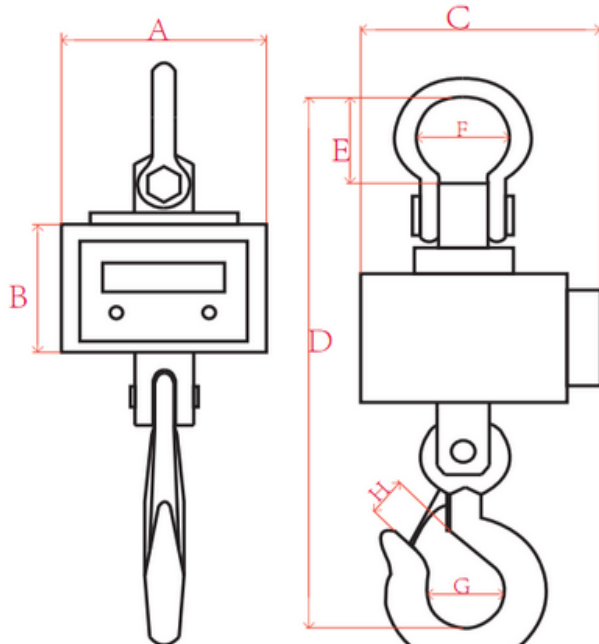

| Model | Max Capacity kg | Division kg | Number of divisions | Crane scale Size mm | | | | | | | | Weight kg |
|---------|--------------------|----------------|------------------------|---------------------|-----|-----|------|-----|-----|-----|-----|--------------|
| | | | | A | B | C | D | E | F | G | H | |
| OCS-20T | 20000 | 10 | 2000 | 305 | 200 | 310 | 840 | 104 | 124 | 105 | 80 | 85 |
| OCS-30T | 30000 | 10 | 3000 | 305 | 200 | 310 | 1002 | 106 | 245 | 130 | 280 | 115 |

Functions

| | |
|------------------------|------------------------------|
| Zero | Digital Calibration |
| Tare | 3-point Linearity Correction |
| Hold | lb/kg Switch |
| Battery Supervision | Division Switch |
| Overload Alarm/ Record | Gravity Acceleration Set |

Specification

| | |
|----------------|----------|
| Accuracy class | OIML III |
| Tare range | 100%F.S. |
| Settling Time | 5-8s |
| Safe Overload | 125%F.S. |
| Limited Load | 400%F.S. |

| | |
|------------------|------------|
| Overload alarm | 100%F.S. |
| Battery | 6V/12AH |
| Work Temperature | -10°C~40°C |
| Battery life | >80h |

Included Accessory



Battery



Remote control



Adaptor